

Application Note

AN-ODE-02

PI closed loop feedback control applications

Author: Peter Evans, Invertek Drives Ltd

Revision: 1.00 3 September 2008

General

Optidrive E2 has a built-in flexible PI feedback controller that can be used for a variety of process control applications. Typical applications include pressure control, flow rate control, temperature control etc.

This document describes the setup procedure for each of the operating modes available.

PI Overview

PI (Proportional- & Integral) control is widely used in many applications. A PI system requires:

Setpoint Signal (reference) – This is the desired operating point of the system proportional to the feedback signal. E.g. a pressure level which the pump is required to maintain, e.g. 1.5 Bar

Feedback Signal – this is the feedback signal proportional to the range of the feedback transducer. E.g. a pressure transducer has a range of 0-10 Bar for a 4-20mA signal range.

The drive will continuously monitor the feedback signal and compare it to the setpoint, and then adjust the output speed automatically to try to maintain the correct setpoint level.

Configuration Parameters

P-44 PI Setpoint (reference):

For a simple system with a fixed setpoint, the value for P-44 can be calculated from the transducer range.

E.g. if a system is required to hold a constant pressure of 1.5 Bar, and uses a transducer for feedback with measurement range 0 to 10 Bar, the value of P-44 can be calculated as

$$\frac{1.5\text{Bar} \times 100\%}{10\text{Bar}} = 15\%$$

P-41 PI Gain:

In simple terms, the PI gain parameter controls how great a variation in pump speed will be seen relative to a change in pressure. If the value used is too high, the pump will continuously change speed, and the pressure will be unstable. Typically on a pump system, the factory set value of 1 will provide good performance. If the pump speed is unstable, reduce the value.

P-42 PI Integral Time:

The Optidrive monitors the change of feedback over time to determine the average pressure and how rapidly it is changing. This time filter helps to provide smooth operation. In most cases, the factory set value of 1 second provides good operation, however the value may need to be increased on systems where the pressure changes relatively slowly in the system.

P-43 PI controller operating mode selection:

The PI controller mode is set using parameter P-43.

In all cases, the P-43 allows the user to select either direct PI control, where an increase in the speed of the motor increases the feedback value, or to select inverse mode, where an increase in the speed of the motor reduces the feedback value.

P-43	Function	Typical Application	Explanation
0	Direct mode	compressor control	INCREASE in motor speed signal for a INCREASE in feedback signal
1	Inverse mode	condenser fan control	INCREASE in motor speed signal for a DECREASE in feedback signal

P-46 PI feedback Select:

The PI feedback can be selected from 3 different sources:

Value	Feedback Signal	Format of the feedback
0	Analog Input 2 (T4)	P-47
1	Analog Input 1 (T6)	P-16
2	Motor load current	Fixed

By default the feedback signal is set to Analog Input 2 on terminal 4

The format of the feedback signal can be configured by setting the format of the analog input in use as required. Most feedback transducers use the 4..20mA format.

If analog input 1 is selected as a feedback signal, digital input 3 (2nd analog input) can then be used as an external trip input which enables the user to connect a PTC motor thermistor for motor protection purposes and by setting P-15=3.

This external trip function is not available if 2nd analog input is selected as PI feedback input.

Feedback Transducers

There are generally two types of transducers, and an example of how to connect each of these to the drive is shown below. When connecting a 2-wire feedback transducer (e.g. 4..20mA type), check that the transducer is suitable for 24V operation, then connect the transducer supply to pin 1 and the transducer output to pin 4.

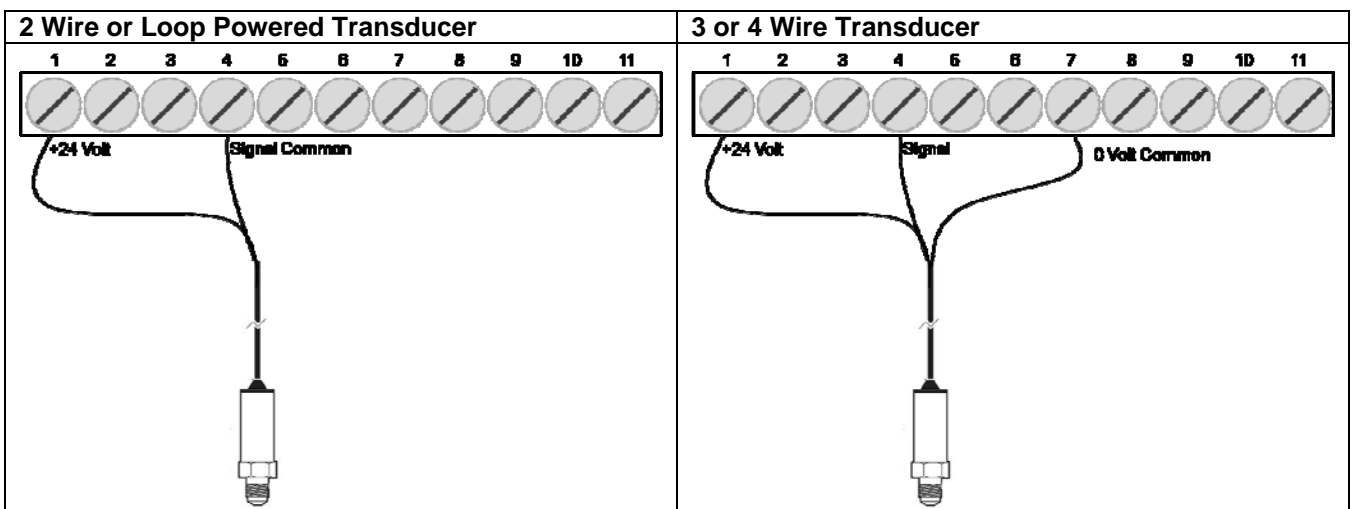

P-44 PI reference select:

The PI controller reference can be given by an external analog input signal or by digital preset value depending on application requirements. This is set up using P44.

P-44	Description
0	PI control using the digital preset value for the reference input. The digital preset reference value is defined in Parameter P3-06, which will give a 0 to 100% full range of feedback value as reference value.
1	PI control using analog input 1 (T6) for the reference input.

Note :

The user has to adjust the PI control parameters (P-gain, I-gain) in P-41 and P-42 respectively to get the best control performance. The values will vary depending on system inertia and the time constant (rate of change) of the system being controlled.

Standby Function

The Optidrive E2 has a built in Standby function, which allows the pump to automatically switch off completely when the motor is not required i.e. running at setpoint level. This function should only be used on systems where the setpoint can be maintained even when the motor is stopped.

In order to use this function, the speed reference on the drive must be at 0.0Hz for 20 seconds after which the Optidrive will switch off the motor, and the display will show **Standby**.

For applications where a minimum operating frequency is required to protect the motor from overheating. The use of skip frequencies is possible to avoid operation below the minimum operating point frequency (typically between 20-30Hz).

Standby Function with skip frequencies

Parameter description:

Parameter	Function	Explanation
P-26	Skip frequency hysteresis band	Set P-09 before adjusting. Speed reference held at upper or lower skip frequency limit until input signal reaches the opposite skip frequency limit. Speed ramps through the skip frequency band at a rate set by P-03 and P-04.
P-27	Skip frequency	Set P-09 before adjusting. Skip frequency centre point

Example Values:

Minimum speed to be 24Hz then ramp down to 0Hz before entering **Standby** after 20 seconds

$$P-26 = 24\text{Hz}$$

$$P-27 = P-26 / 2 = 24\text{Hz} / 2 = 12\text{Hz}$$

Application Examples:

Pressure Control – Simple Fixed PI Setpoint

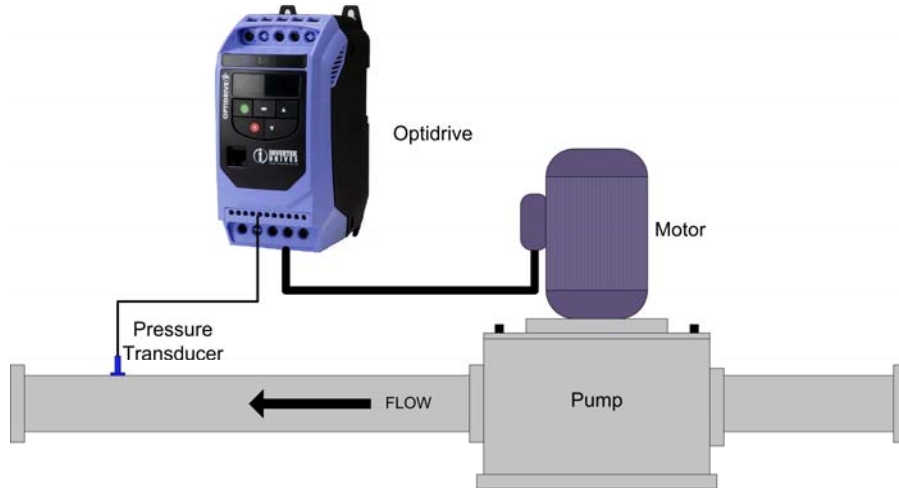

Par	Function	Example Setting	Explanation
P-03	Acceleration Ramp Time	10 – 30 seconds	Allows for smooth starting and stopping of the system
P-04	Deceleration Ramp Time	10 – 30 seconds	
P-06	Energy Optimiser	1	Energy optimiser enabled
P-07	Motor Rated Voltage	-	Enter the values from the motor nameplate, to avoid damaging the motor.
P-08	Motor Rated Current	-	
P-09	Motor Rated Frequency	-	
P-12	Control Selection	5	Enables PI Control
P-14	Access Code	101	Allows Access to PI Parameters
P-47	2 nd Analog Input Format	4-20mA	Set to match the transducer signal type
P-41	PI Proportional Gain	0.5 – 2	System Dependant
P-42	PI Integral Time	1 – 5 seconds	System Dependant
P-43	PI Mode Select	0	Direct Operation – INCREASE in motor speed signal for a INCREASE in feedback signal
P-44	PI Setpoint Selection	1	Digital Setpoint with level set in P-45
P-45	PI Setpoint (reference)	-	Set to desired operating level.

Connections:

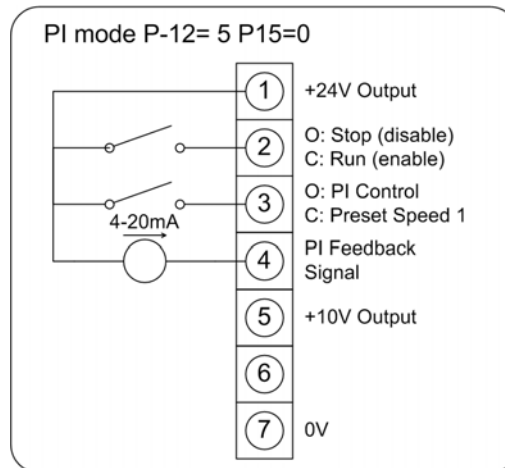

Pressure Control – Variable PI Setpoint with local/ remote operation.

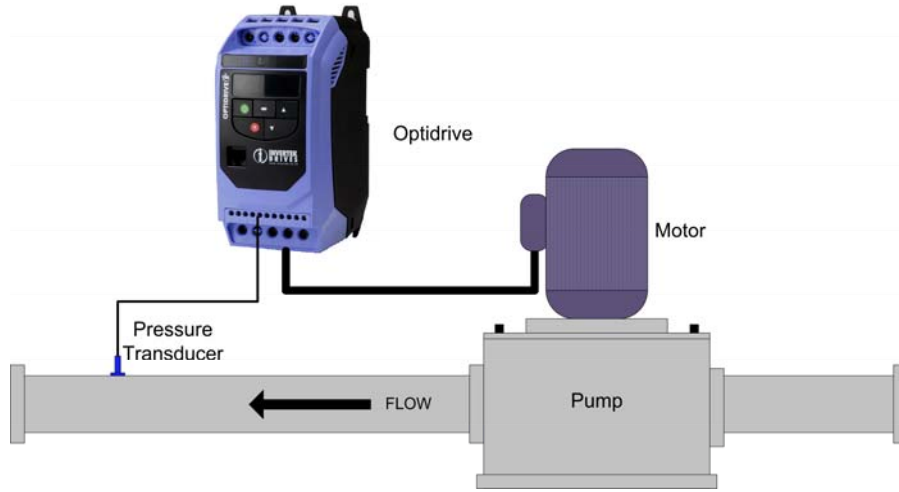

Par	Function	Example Setting	Explanation
P-03	Acceleration Ramp Time	10 – 30 seconds	Allows for smooth starting and stopping of the system
P-04	Deceleration Ramp Time	10 – 30 seconds	
P-06	Energy Optimiser	1	Energy optimiser enabled
P-07	Motor Rated Voltage	-	Enter the values from the motor nameplate, to avoid damaging the motor.
P-08	Motor Rated Current	-	
P-09	Motor Rated Frequency	-	
P-12	Control Selection	5	Enables PI Control
P-14	Access Code	101	Allows Access to PI Parameters
P-15	Terminal Configuration		See below
P-47	2 nd Analog Input Format	4-20mA	Set to match the transducer signal type
P-41	PI Proportional Gain	0.5 – 2	System Dependant
P-42	PI Integral Time	1 – 5 seconds	System Dependant
P-43	PI Mode Select	0	Direct Operation – INCREASE in motor speed signal for a INCREASE in feedback signal
P-44	PI Setpoint Selection	0	Analog Setpoint with level set from external signal e.g. potentiometer

Connections:

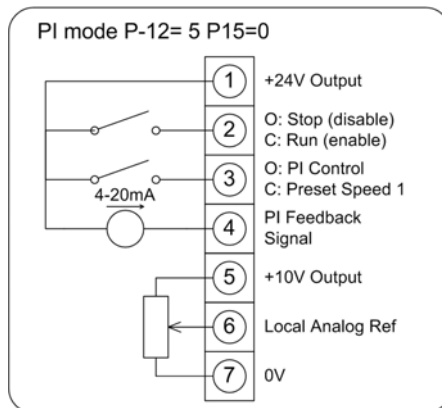

Remote Control (PI)
Local Control

Control set by pressure level
Speed Set by Preset Speed 1 (P-20)

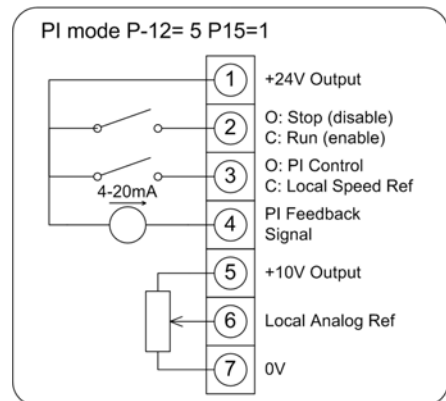

Control set by pressure level
Speed set by potentiometer

Blower / Compressor Control using pressure feedback

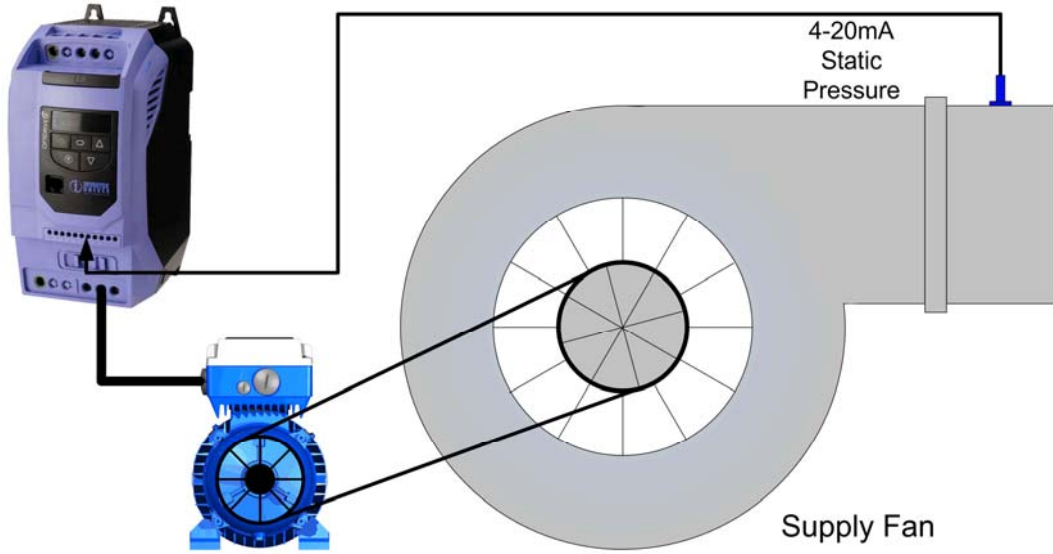

Par	Function	Example Setting	Explanation
P-03	Acceleration Ramp Time	10 – 30 seconds	Allows for smooth starting and stopping of the system
P-04	Deceleration Ramp Time	10 – 30 seconds	
P-06	Energy Optimiser	1	Energy optimiser enabled
P-07	Motor Rated Voltage	-	Enter the values from the motor nameplate, to avoid damaging the motor.
P-08	Motor Rated Current	-	
P-09	Motor Rated Frequency	-	
P-12	Control Selection	5	Enables PI Control
P-14	Access Code	101	Allows Access to PI Parameters
P-15	Terminal Configuration		See below
P-47	2 nd Analog Input Format	4-20mA	Set to match the transducer signal type
P-41	PI Proportional Gain	0.5 – 2	System Dependant
P-42	PI Integral Time	1 – 5 seconds	System Dependant
P-43	PI Mode Select	0	Direct Operation – INCREASE in motor speed signal for a INCREASE in feedback signal
P-44	PI Setpoint Selection	0	Analog Setpoint with level set from external signal e.g. potentiometer

Connections:

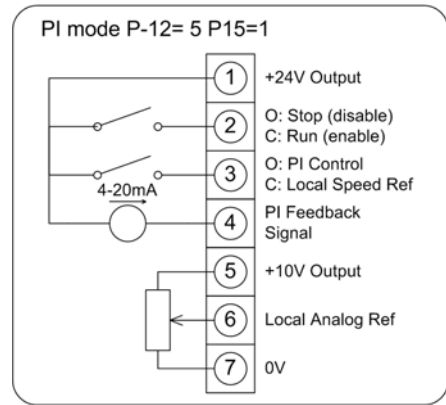
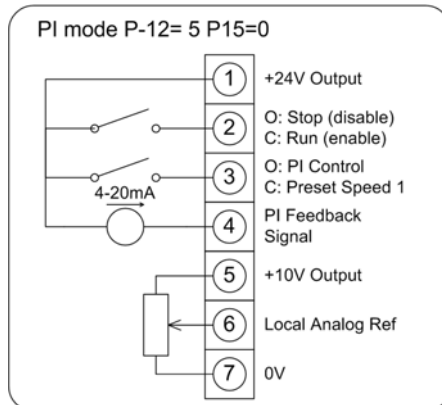

Remote Control (PI)
Local Control

Control set by pressure level
Speed Set by Preset Speed 1 (P-20)

Control set by pressure level
Speed set by potentiometer

Temperature Control using temperature feedback

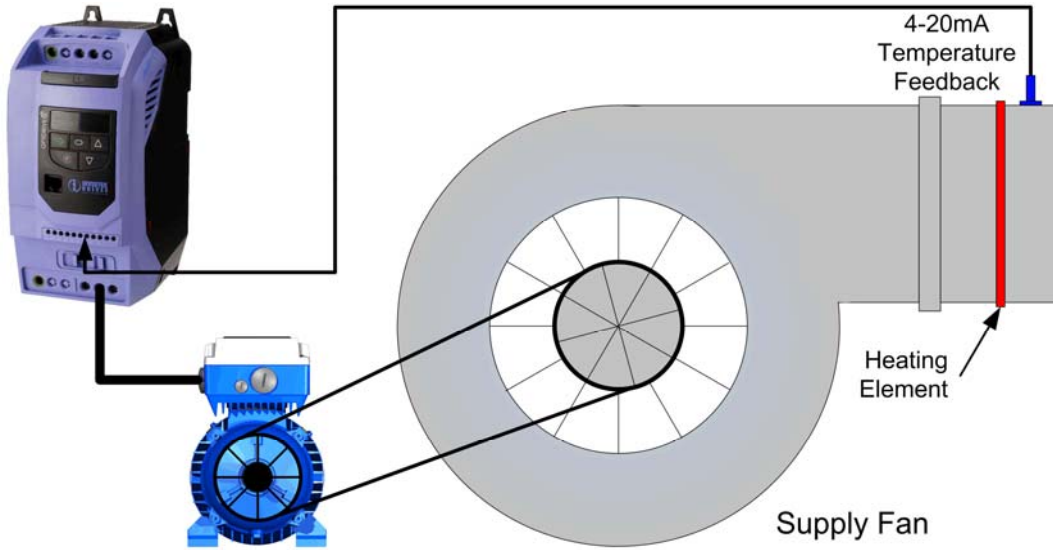

Par	Function	Example Setting	Explanation
P-03	Acceleration Ramp Time	10 – 30 seconds	Allows for smooth starting and stopping of the system
P-04	Deceleration Ramp Time	10 – 30 seconds	
P-06	Energy Optimiser	1	Energy optimiser enabled
P-07	Motor Rated Voltage	-	Enter the values from the motor nameplate, to avoid damaging the motor.
P-08	Motor Rated Current	-	
P-09	Motor Rated Frequency	-	
P-12	Control Selection	5	Enables PI Control
P-14	Access Code	101	Allows Access to PI Parameters
P-15	Terminal Configuration		See below
P-47	2 nd Analog Input Format	4-20mA	Set to match the transducer signal type
P-41	PI Proportional Gain	0.5 – 2	System Dependant
P-42	PI Integral Time	1 – 5 seconds	System Dependant
P-43	PI Mode Select	1	Inverse Operation – INCREASE in motor speed signal for a DECREASE in feedback signal
P-44	PI Setpoint Selection	0	Analog Setpoint with level set from external signal e.g. potentiometer

Connections:

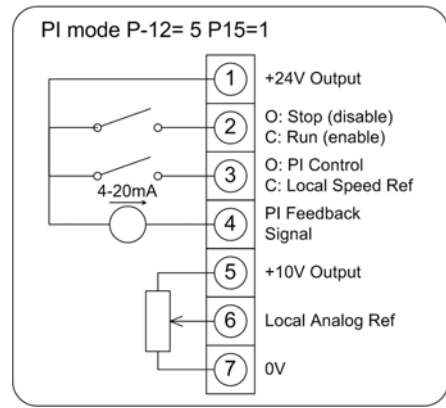
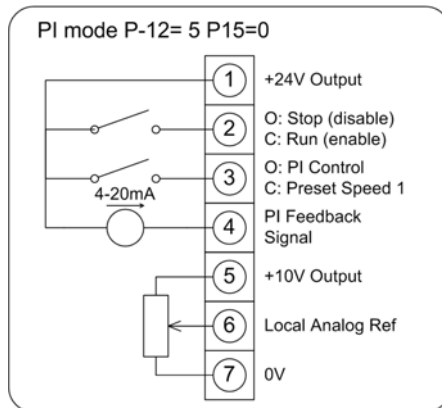

Remote Control (PI)
Local Control

Control set by pressure level
Speed Set by Preset Speed 1 (P-20)

Control set by pressure level
Speed set by potentiometer